

be anticipated for a singly bridged  $\text{Mn}_2(\text{CO})_9^-$  species, with the unpaired electron occupying a remote  $\sigma^*$  SOMO of appropriate symmetry ( $b_2$  in  $C_{2v}$ ). Furthermore,  $g$  shifts would be small for a species having a half-filled level well separated in energy from others. The principal  $g^2$  values for the center in  $\text{Mn}_2(\text{CO})_{10}$  are, in fact, all very close to the free-spin value of 4.009 (Table I).

Examination of the structures of the binuclear metal carbonyls shows that bridging is favored when the metal atom possesses more than seven d electrons. Even in  $\text{Mn}_2(\text{CO})_{10}$ , the equatorial C-Mn-Mn angles<sup>14</sup> suggest a tendency toward carbonyl bridging. One should not, therefore, be too surprised

to find a single bridge in  $\text{Mn}_2(\text{CO})_9^-$ , a  $d^7d^8$  species. This molecule has only one electron less than  $\text{Fe}_2(\text{CO})_9$ , which has three carbonyl bridges.

The observation of a single site for the radical in the monoclinic crystal restricts the direction of the twofold axis for  $\text{Mn}_2(\text{CO})_9^-$  to one of two possibilities. It either lies in the  $ac$  plane or is parallel to the twofold axis ( $b$ ) of the crystal. The latter choice is deemed more likely since the radicals would then transform according to the symmetry of the crystal space group.

Registry No.  $\text{Mn}_2(\text{CO})_9^-$ , 83510-93-4;  $\text{Mn}_2(\text{CO})_{10}$ , 10170-69-1.

Contribution from the Department of Chemistry,  
Northern Illinois University, DeKalb, Illinois 60115

## Electronic Absorption and Magnetic Circular Dichroism of the Linear Diaquodimercury(I) Cation

W. ROY MASON

Received April 28, 1982

Solution electronic absorption and magnetic circular dichroism (MCD) spectra for  $[\text{Hg}_2(\text{H}_2\text{O})_2](\text{ClO}_4)_2 \cdot 1.3\text{H}_2\text{O}$  in 0.100 M  $\text{HClO}_4$  are reported between 260 and 190 nm. Absorption measurements for acetonitrile solutions are also reported. An intense band and accompanying negative  $B_0$  term observed at  $4.2 \mu\text{m}^{-1}$  is assigned as  $^1\Sigma_g^+ \rightarrow \Sigma_u^+(a^1\Sigma_u^+)$ , the excited state arising from the  $(3\sigma_g^+)(3\sigma_u^+)$  excited configuration  $[\sigma(6s-6s) \rightarrow \sigma^*(6s-6s)]$ . Two weaker bands observed at 4.68 and  $4.91 \mu\text{m}^{-1}$  were assigned to transitions to the  $\Pi_u(a^3\Pi_u)$  and  $\Sigma_u^+(a^3\Pi_u)$  spin-orbit states of the  $(3\sigma_g^+)(2\pi_u)$  excited configuration  $[\sigma(6s-6s) \rightarrow \pi(6p_x, 6p_y-6p_x, 6p_y)]$ . A negative  $A_1$  term is observed for the band at  $4.68 \mu\text{m}^{-1}$ . The bonding in the  $\text{Hg}_2(\text{H}_2\text{O})_2^{2+}$  ion is discussed in terms of orbital contributions.

### Introduction

The dinuclear dimercury(I) ion,  $\text{Hg}_2^{2+}$ , is unique in its stability in aqueous acid solutions, in the absence of strongly coordinating ligands that promote disproportionation to  $\text{Hg}(0)$  and  $\text{Hg}(\text{II})$ .<sup>1</sup> X-ray scattering measurements on aqueous solutions of the perchlorate salt indicate two water molecules axially coordinated to give the linear  $\text{H}_2\text{O}-\text{Hg}-\text{Hg}-\text{OH}_2^{2+}$  ion with two-coordination about each Hg.<sup>2</sup> This same ion is found in solid crystalline hydrates such as  $\text{Hg}_2(\text{NO}_3)_2 \cdot 2\text{H}_2\text{O}^3$  and  $\text{Hg}_2(\text{ClO}_4)_2 \cdot 4\text{H}_2\text{O}$ .<sup>2</sup> The  $\text{Hg}_2(\text{H}_2\text{O})_2^{2+}$  ion is of interest because it is one of the simplest stable ions that contain a metal-metal single bond. Even so, the nature of the Hg-Hg bond in Hg(I) compounds is not well understood. For example, the bond energy is not known precisely,<sup>4</sup> the  $\nu_{\text{Hg}-\text{Hg}}$  stretch is sensitive to the solid or solution environment,<sup>1</sup> and the nature of the orbitals contributing to the bond strength is not known for certain. Therefore, in order to provide a spectroscopic basis for discussion of the electronic structure of the  $\text{Hg}_2(\text{H}_2\text{O})_2^{2+}$  ion, prompted in part by our interest in electronic structure of two-coordinate complexes generally, we report some electronic absorption and magnetic circular dichroism (MCD) spectra for  $\text{Hg}_2(\text{H}_2\text{O})_2^{2+}$  in dilute acid solution. Electronic spectra of  $\text{Hg}_2^{2+}$  in the UV region have been reported previously,<sup>5</sup> but the measurements appear incomplete and the spectra were not assigned. Also, counterions such as  $\text{NO}_3^-$

absorb strongly in the UV region and tend to obscure the features of the  $\text{Hg}_2^{2+}$  ion. In the present study  $\text{ClO}_4^-$  served as the counterion and  $\text{HClO}_4$  was used to maintain the acidity of the solutions; neither has strong absorptions in the UV region below  $5.2 \mu\text{m}^{-1}$ .

### Experimental Section

Mercury(I) perchlorate hydrate was purchased from Alfa-Ventron (Danvers, MA) and analyzed for water content by precipitation of  $\text{Hg}_2\text{Cl}_2$ ; the hydration was found to be 3.3 water molecules/ $\text{Hg}_2(\text{ClO}_4)_2$  formula unit. All aqueous spectra were obtained in 0.100 M  $\text{HClO}_4$  solution to prevent hydrolysis. Absorption spectra were also obtained by dissolving the hydrated salt in Spectroquality acetonitrile.

Absorption and MCD spectra were determined with a spectrometer that allows synchronous simultaneous measurement along the same light path. The spectrometer has been described elsewhere recently.<sup>6</sup> MCD spectra were obtained with both a 1-T permanent magnet (sample path length 0.100 cm) and a 7-T superconducting selenoid (Oxford Instruments SM2-7, with a room-temperature bore; sample path length 1.00 cm). The spectral bandwidth was 0.5 nm throughout the wavelength range investigated, and no spectral feature was machine limited in resolution. Absorption measurements were also made on a Cary 1501. All measurements were made at room temperature and Beer's law was found to hold for both aqueous and acetonitrile solutions.

### Results and Discussion

**Electronic Absorption and MCD Spectra.** Figure 1 presents the electronic absorption and 7.0-T MCD spectra of  $\text{Hg}_2(\text{H}_2\text{O})_2^{2+}$  in 0.100 M  $\text{HClO}_4$ . Quantitative spectral data are collected in Table I. The absorption spectra consist of three intense bands, the lowest energy band (band I) being the most

- (1) McAuliffe, C. A. "The Chemistry of Mercury"; Macmillan: London, 197; p 51 ff and references cited therein.
- (2) Johansson, G. *Acta Chem. Scand.* **1966**, *20*, 553.
- (3) Grdenic, D. *J. Chem. Soc.* **1956**, 1312.
- (4) Kleier, D. A.; Wadt, W. R. *J. Am. Chem. Soc.* **1980**, *102*, 6909.
- (5) Higginson, W. C. E. *J. Chem. Soc.* **1951**, 1438.

- (6) Mason, W. R. *Anal. Chem.* **1982**, *54*, 646.

Table I. Spectral Data for  $\text{Hg}_2(\text{ClO}_4)_2$ 

band no.	absorption <sup>a, b</sup>			MCD <sup>a</sup>		
	$\lambda$ , nm	$\bar{\nu}$ , $\mu\text{m}^{-1}$	$\epsilon$ , $\text{M}^{-1} \text{cm}^{-1}$	$\lambda$ , nm	$\bar{\nu}$ , $\mu\text{m}^{-1}$	$\Delta\epsilon$ , $\text{M}^{-1} \text{cm}^{-1} \text{T}^{-1}$
I	236 (234)	4.23 (4.28)	28 800 (24 900)	235	4.25	-3.21
II	214 (215)	4.68 (4.65)	10 900 (13 200)	218	4.58	+0.99
				215	4.65	0
				210	4.77	-1.99
III	204 (206)	4.91 (4.86)	9 700 (9800) <sup>d</sup>	203	4.94	+0.21

<sup>a</sup> 0.100 M  $\text{HClO}_4$ . <sup>b</sup> Data in parentheses for acetonitrile solution. <sup>c</sup> A term. <sup>d</sup> Shoulder.

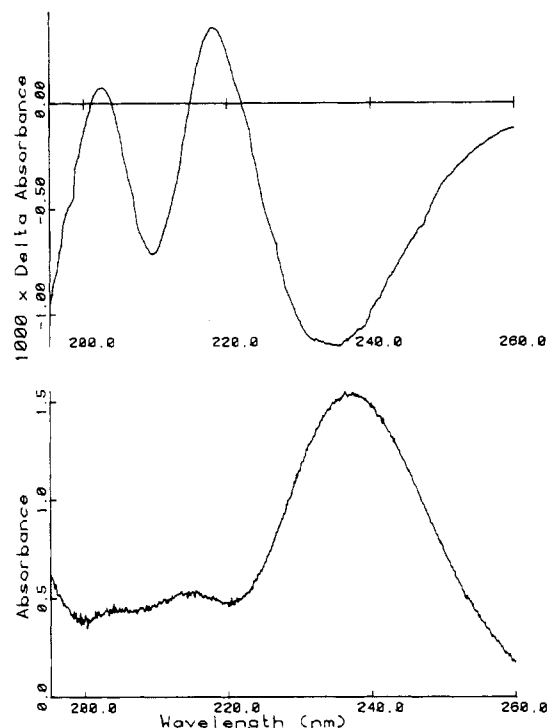

Figure 1. Electronic absorption (lower curve) and MCD (upper curve) spectra for  $5.1 \times 10^{-5} \text{ M } [\text{Hg}_2(\text{H}_2\text{O})_2](\text{ClO}_4)_2$  in 0.100 M  $\text{HClO}_4$ , with a magnetic field of 7.0 T. Path length = 1.00 cm; spectral bandwidth = 0.5 nm. Spectra are corrected for solvent blank.

intense and broadest. The first two bands (bands I and II) were reported previously,<sup>5</sup> and the wavelengths and absorptivities agree favorably with the present measurements. The MCD shows a broad negative  $B_0$  term for band I and a clear negative  $A_1$  term for band II (see ref 7 for a discussion of MCD spectroscopy and  $A_1$  and  $B_0$  term sign conventions). The MCD term for band III is not so clear but appears to be a weak positive  $B_0$  term, which overlaps with the negative portion of the  $A_1$  term of band II. At energies higher than that of band III there is a strongly rising absorbance and increasing negative  $\Delta A$  in the MCD that are not due to the solvent medium, thus indicating additional intense bands  $> 5.2 \mu\text{m}^{-1}$ . Data are also included in Table I for acetonitrile solutions of  $\text{Hg}_2(\text{ClO}_4)_2 \cdot 3.3\text{H}_2\text{O}$ . The three bands are also observed shifted only slightly. The solution species in acetonitrile is not definitely known but likely is  $\text{Me}-\text{CN}-\text{Hg}-\text{Hg}-\text{NC}-\text{Me}^{2+}$  in view of the solvent concentration compared to that of the  $\text{H}_2\text{O}$  from the hydrated salt. If this is the case, then there is very little change in the absorption spectrum on  $\text{H}_2\text{O}$  replacement by MeCN.

**Energy Levels and Electronic States.** As a basis for interpreting the absorption and MCD spectra of the  $\text{Hg}_2(\text{H}_2\text{O})_2^{2+}$  ion, Figure 2 presents a molecular orbital energy-level diagram for the linear ion. The  $z$  axis taken to be the molecular axis. The ion is diamagnetic with the highest filled orbital  $3\sigma_g^+$

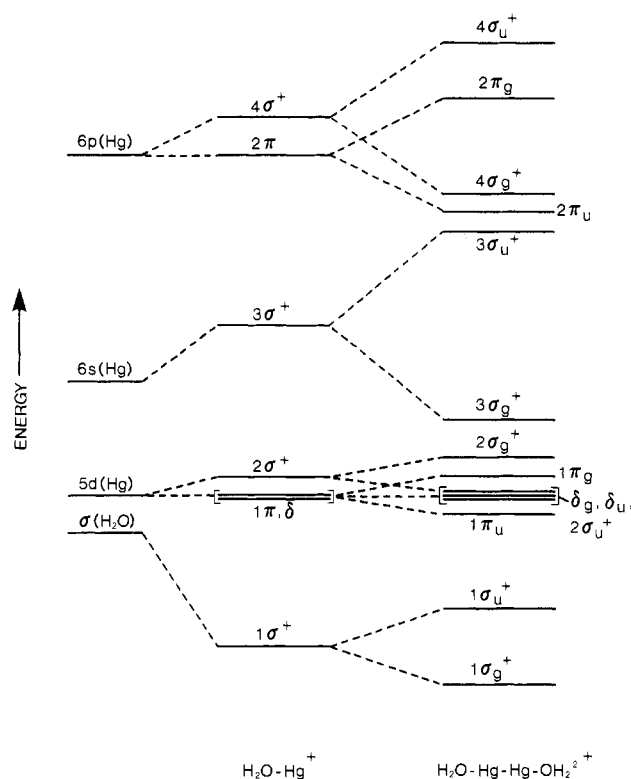

Figure 2. Molecular orbital energy levels for  $\text{Hg}_2(\text{H}_2\text{O})_2^{2+}$  showing their relation to the orbitals of  $\text{Hg}(\text{H}_2\text{O})^+$ , Hg atomic orbitals, and a  $\sigma$ -donor orbital ( $\sim \text{sp}^3$  hybrid) on  $\text{H}_2\text{O}$ .

Table II. Excited Configurations and Electronic States

excited config <sup>a</sup>	electronic states	spin-orbit states
$(3\sigma_g^+)(3\sigma_u^+)$	$a^1\Sigma_u^+$ $a^3\Sigma_u^+$	$\Sigma_u^+$ $\Sigma_u^-, \Pi_u$
$(3\sigma_g^+)(2\pi_u)$	$a^1\Pi_u$ $a^3\Pi_u$	$\Pi_u$ $\Pi_u, \Sigma_u^+, \Sigma_u^-, \Delta_u$
$(2\sigma_g^+)(3\sigma_u^+)$	$b^1\Sigma_u^+$ $b^3\Sigma_u^+$	$\Sigma_u^+$ $\Sigma_u^-, \Pi_u$
$(1\pi_g)^3(3\sigma_u^+)$	$b^1\Pi_u$ $b^3\Pi_u$	$\Pi_u$ $\Pi_u, \Sigma_u^+, \Sigma_u^-, \Delta_u$
$(1\delta_g)^3(3\sigma_u^+)$	$^1\Delta_u$ $^3\Delta_u$	$\Delta_u$ $\Delta_u, \Pi_u, \Phi_u$

<sup>a</sup> Filled orbitals omitted.

giving a nondegenerate ground state designated  $^1\Sigma_g^+$ . The electronic states of the lowest energy excited configurations are given in Table II. Since Hg(I) has large spin-orbit coupling ( $\zeta_{5d} \approx \zeta_{6p} \approx 0.6 \mu\text{m}^{-1}$ ),<sup>8</sup> the spin-orbit states of each excited configuration are listed in Table II. In  $D_{\infty h}$  symmetry only transitions to  $\Sigma_u^+$  ( $z$  polarized) and  $\Pi_u$  ( $x, y$  polarized) will be allowed by dipole selection rules, but the strong spin-orbit coupling will mix singlet and triplet states significantly so that transitions to formally spin-forbidden triplet states may have considerable intensity.

(7) Stephens, P. J. *Adv. Chem. Phys.* **1976**, *35*, 197 and references cited therein.

(8) Moore, C. E. *Natl. Bur. Stand. (U.S.), Circ.* **1958**, *No. 467*, Vol. III.

**Spectral Assignments.** From both energetic and intensity considerations band I is logically assigned as  ${}^1\Sigma_g^+ \rightarrow \Sigma_u^+(a^1\Sigma_u^+)$  arising from the  $(3\sigma_g^+)(3\sigma_u^+)$  excited configuration. The observed  $B_0$  term in the MCD is consistent with a transition to a nondegenerate state. Both absorption and MCD show considerable broadness on the low-energy side of band I, which may indicate one or more weaker unresolved transitions. Specifically, the  $\Pi_u(a^3\Sigma_u^+)$  and  $\Sigma_u^-(a^3\Sigma_u^+)$  states are expected to be lower in energy than  $\Sigma_u^+(a^1\Sigma_u^+)$ . However, the  $\Sigma_u^-(a^3\Sigma_u^+)$  is orbitally forbidden and a transition to this state will be very weak. Similarly, a transition to the  $\Pi_u(a^3\Sigma_u^+)$  state will also be very weak since it can gain intensity via spin-orbit coupling only indirectly through  $6s-6p_z$  mixing or even less likely through  $5d-6s$  mixing. The MCD  $A_1$  term for this transition is expected to be positive but very weak due to its small electric dipole and therefore unresolved beneath the  $B_0$  term associated with the  $\Sigma_u^+(a^1\Sigma_u^+)$  state.

The presence of the negative  $A_1$  term in the MCD for band II indicates a transition to a degenerate  $\Pi_u$  state. From consideration of the relative energies of the  $5d$ ,  $6s$ , and  $6p$  Hg orbitals obtained from atomic spectral data,<sup>8</sup> the most likely lowest energy  $\Pi_u$  states arise from the  $(3\sigma_g^+)(2\pi_u)$  configuration. If the  $3\sigma_u^+$  and  $2\pi_u$  orbitals are approximated as combinations of  $6s$  and  $6p_x$ ,  $6p_y$  atomic orbitals, respectively, then the  $\Pi_u(a^1\Pi_u)$  state of the  $(3\sigma_g^+)(2\pi_u)$  configuration is predicted to have a *positive*  $A_1$  term while the  $\Pi_u(a^3\Pi_u)$  state is predicted to have a *negative*  $A_1$  term. Since the observed MCD term is negative, band II is assigned as a transition to  $\Pi_u(a^3\Pi_u)$ . The intensity of this band can be explained since there will be direct spin-orbit mixing between  $\Pi_u(a^1\Pi_u)$  and  $\Pi_u(a^3\Pi_u)$  which is expected to be extensive because of the magnitude of  $\zeta_{6p}$  ( $\sim 0.6 \mu\text{m}^{-1}$ ). Some rough calculations<sup>9</sup> indicate 35–40% singlet character in  $\Pi_u(a^3\Pi_u)$  and a splitting of  $1.2-1.3 \mu\text{m}^{-1}$  between the  $\Pi_u(a^3\Pi_u)$  and the  $\Pi_u(a^1\Pi_u)$  states if the singlet-triplet energy separation in the absence of spin-orbit coupling is  $0.2-0.4 \mu\text{m}^{-1}$ . Thus, if band II at  $4.68 \mu\text{m}^{-1}$  is assigned as  $\Pi_u(a^3\Pi_u)$ , the  $\Pi_u(a^1\Pi_u)$  state is predicted to lie at  $5.8-5.9 \mu\text{m}^{-1}$ , well beyond the range of our measurements. It should be pointed out however that the  $\Pi_u$  states of the  $(1\Pi_g^3)(3\sigma_u^+)$  excited configuration are also predicted to have a *positive*  $A_1$  term for  $\Pi_u(b^1\Pi_u)$  and a *negative*  $A_1$  term for  $\Pi_u(b^3\Pi_u)$ . Therefore, an analogous assignment of band II to  $\Pi_u(b^3\Pi_u)$  with  $\Pi_u(b^1\Pi_u)$  lying  $1.0-1.2 \mu\text{m}^{-1}$  higher in energy ( $\zeta_{5d} \approx 0.6 \mu\text{m}^{-1}$  also) cannot be ruled by the MCD results. However, the Hg  $5d$  orbitals are some  $3.6 \mu\text{m}^{-1}$  more stable than the  $6s$ ,<sup>8</sup> leading to a  $6.5-7 \mu\text{m}^{-1}$  separation between the  $1\pi_g$  and  $3\sigma_u^+$  orbitals. Even with strong spin-orbit interaction, the  $\Pi_u(b^3\Pi_u)$  state would not be expected below  $5.2 \mu\text{m}^{-1}$ . The differences in electron repulsion between the various electronic configurations are not known, but it is unlikely that they would be large enough to significantly change the relative energy ordering of  $\Pi_u(a^3\Pi_u) \ll \Pi_u(b^3\Pi_u)$ .

The assignment of band III is to  $\Sigma_u^+(a^3\Pi_u)$  of the  $(3\sigma_g^+)(2\pi_u)$  excited configuration. The MCD is quite weak but appears to show a positive  $B_0$  term, consistent with a transition to a nondegenerate state. The placement of  $\Sigma_u^+(a^3\Pi_u)$  near the observed energy band III is entirely reasonable in view of the assignment of band II to  $\Pi_u(a^3\Pi_u)$ . If the alternative assignment of band  $\Pi_u(b^3\Pi_u)$  is adopted, then band III must be due to  $\Sigma_u^+(b^3\Pi_u)$ , but the arguments above

for favoring the assignment of band II to  $\Pi_u(a^3\Pi_u)$  on energetic grounds would apply to the  $\Sigma_u^+$  state also.

There are few literature data available for comparison with the assignments of the  $\text{Hg}_2(\text{H}_2\text{O})_2^{2+}$  spectra given here, but two cases are worthy of note. First, some recent ab initio valence-bond calculations<sup>4</sup> on the linear Cl–Hg–Hg–Cl molecule suggest that the transitions  ${}^1\Sigma_g^+ \rightarrow {}^1\Pi_u$  and  ${}^1\Sigma_g^+ \rightarrow {}^1\Sigma_u^+$ , the excited states of which are analogous to the  $a^1\Sigma_u^+$  and  $a^1\Pi_u$  states of  $\text{Hg}_2(\text{H}_2\text{O})_2^{2+}$ , should lie at energies  $< 5 \mu\text{m}^{-1}$ . The calculations place the  ${}^1\Pi_u$  state lower in energy than  ${}^1\Sigma_u^+$  for Cl–Hg–Hg–Cl. Some preliminary spectral measurements<sup>4</sup> on  $\text{Hg}_2\text{Cl}_2$  in the vapor phase revealed a broad unstructured band at  $\sim 4.0 \mu\text{m}^{-1}$  and a structured band at  $5.2 \mu\text{m}^{-1}$ . The lower energy band was suggested as due to a transition to the  ${}^1\Pi_u$  state, but a transition to the  ${}^1\Sigma_u^+$  state may also be superimposed. No assignments were given for the  $5.2 \mu\text{m}^{-1}$  band, and it was noted that prominent absorptions due to Hg vapor were present, indicating disproportionation. The lack of an  $A_1$  term for band I of  $\text{Hg}_2(\text{H}_2\text{O})_2^{2+}$  here argues strongly for a  $\Sigma_u^+$  state lowest in energy when  $\text{H}_2\text{O}$  is the axial ligand. A reversal in energy of the  $\Sigma_u^+$  and  $\Pi_u$  states on replacement on  $\text{H}_2\text{O}$  by  $\text{Cl}^-$  would be interesting, but confirmation of such a reversal will require more reliable spectroscopic data for  $\text{Hg}_2\text{Cl}_2$ . Unfortunately  $\text{Hg}_2\text{Cl}_2$  is not very soluble in aqueous solution so comparable solution measurements will be difficult.

The second case worthy of note is the diatomic  $\text{Au}_2$  molecule, isoelectronic with  $\text{Hg}_2^{2+}$ , which has been investigated in detail both theoretically<sup>10,11</sup> and experimentally.<sup>12</sup> The lowest energy allowed state for  $\text{Au}_2$  is believed to be  ${}^1\Sigma_u^+$ , but extensive involvement of the  $\text{Au}(0)$   $5d$  orbitals in both ground and low-lying excited states is indicated. The  $5d-6s$  energy separation is only  $\sim 1.0 \mu\text{m}^{-1}$  in  $\text{Au}(0)$  compared to  $\sim 3.6 \mu\text{m}^{-1}$  in  $\text{Hg}(I)$ .<sup>8</sup> There will undoubtedly be considerable contraction of the  $5d$  orbitals from  $\text{Au}(0)$  to  $\text{Hg}(I)$  due to the increased nuclear charge, and the participation of the  $5d$  orbitals in bonding in  $\text{Hg}_2(\text{H}_2\text{O})_2^{2+}$  is expected to be greatly reduced. Thus even though the symmetries of the ground and lowest energy allowed excited state are the same for  $\text{Hg}_2(\text{H}_2\text{O})_2^{2+}$  and  $\text{Au}_2$ , the orbital contributions to these are likely different because of the relative atomic orbital energies of  $\text{Hg}(I)$  compared to  $\text{Au}(0)$ .

**Bonding in  $\text{Hg}_2(\text{H}_2\text{O})_2^{2+}$ .** On the basis of the interpretation of the electronic absorption and MCD spectra advanced here, which places electronic states involving the Hg  $6s$  and  $6p$  orbitals at lowest energy, the Hg–Hg bond in  $\text{Hg}_2(\text{H}_2\text{O})_2^{2+}$  is best described as being mostly due to  $6s$ -orbital overlap. Some  $6s-6p_z$  overlap is also possible and may contribute to the bond stability since the Hg–Hg bond appears to be more stable than that of Cs–Cs in  $\text{Cs}_2$ , where the bonding is limited to  $6s$  overlap. It is probable however that the  $6p_z$  orbitals of Hg are also used to extensively in binding to the axially coordinated  $\text{H}_2\text{O}$  molecules. In contrast to the case of  $\text{Au}_2$ , the utilization of the more stable contracted Hg  $5d$  orbitals in bonding is not very great. The  $5d$  orbitals being filled assume part of the spherical “core” of electrons surrounding each Hg atom.

The well-known disproportionations of  $\text{Hg}_2(\text{H}_2\text{O})_2^{2+}$  on reaction with strong  $\sigma$ -donor ligands such as  $\text{OH}^-$ ,  $\text{F}^-$ , or  $\text{CN}^-$  to give  $\text{HgX}_2$  and  $\text{Hg}(0)$  can be understood within the framework of Figure 2 if the initial step involves the replacement of the axially coordinated  $\text{H}_2\text{O}$  by the strong donor  $\text{X}^-$ . On coordination of  $\text{X}^-$  the  $3\sigma_g^+$  bonding orbital will be destabilized as the donor demands  $6s$  character. As the  $3\sigma_g^+$  energy approaches the nonbonding  $6s$ -orbital energy, the

(9) Spin-orbit eigenvectors and eigenvalues were obtained by diagonalizing the secular determinant ( $a^1\Pi_u$  and  $a^3\Pi_u$  are energies in the absence of spin-orbit coupling):

$$\begin{vmatrix} a^1\Pi_u - E & -i\zeta_{6p} \\ i\zeta_{6p} & a^3\Pi_u - E \end{vmatrix} = 0$$

Singlet character was estimated from the coefficient of  $a^1\Pi_u$  in the  $\Pi_u(a^3\Pi_u)$  eigenvector.

(10) Lee, Y. S.; Ermler, W. C.; Pitzer, K. S.; McLean, A. D. *J. Chem. Phys.* **1979**, *70*, 288.

(11) Ermler, W. C.; Lee, Y. S.; Pitzer, K. S. *J. Chem. Phys.* **1979**, *70*, 293.

(12) Ames, L. L.; Barrow, R. F. *Faraday Soc. Trans.* **1967**, *63*, 39.

Hg-Hg bond will disappear, producing  $\text{HgX}^+$  and displacing a Hg atom. The  $\text{HgX}^+$  ion, a Hg(II) species, is expected to use sp-hybrid orbitals and will eventually react with another mole of  $\text{X}^-$  to produce a linear two-coordinate  $\text{HgX}_2$  molecule.

It is tempting to try to correlate the energy of the  $^1\Sigma_u^+ \rightarrow \Sigma_u^+(a^1\Sigma_u^+)$  transition with a dissociation energy of  $\text{Hg}_2(\text{H}_2\text{O})_2^{2+}$  in solution, but such a correlation is difficult at best, and only a crude upper limit estimate could be made and then only if the  $\Sigma_u^+(a^1\Sigma_u^+)$  state is an unbound state. If it is a bound state, then no correlation can be made at all. The broadness of band I may signal an unbound state, but the broadness may be nothing more than unresolved vibrations in

a room-temperature solution spectrum. Further, the uncertainty of the energy difference between the  $\Sigma_u^+(a^1\Sigma_u^+)$  state and the dissociation limit of the ground state, together with differences in solvation energies of the undissociated and dissociated ions, preclude any sound quantitative estimate of the Hg-Hg bond energy.

**Acknowledgment** is made to the donors of the Petroleum Research Fund, administered by the American Chemical Society, for the support of this research.

**Registry No.**  $[\text{Hg}_2(\text{H}_2\text{O})_2](\text{ClO}_4)_2$ , 83546-48-9;  $\text{Hg}_2(\text{H}_2\text{O})_2^{2+}$ , 56650-84-1.

Contribution from the Department of Chemistry, Northeastern University, Boston, Massachusetts 02115

## Thiocyanate-Bridged Transition-Metal Polymers. 4. A Study of the Structural, Electronic, and Magnetic Properties of Some Mono(2,2'-bipyridyl) Transition-Metal Thiocyanates: Zigzag Polymeric Chains Based on $\text{Mn}(\text{bpy})(\text{NCS})_2$ and $\text{Co}(\text{bpy})(\text{NCS})_2$

BRUCE W. DOCKUM, GLENN A. EISMAN, E. H. WITTEN, and WILLIAM MICHAEL REIFF\*

Received February 12, 1982

$\text{Mn}(\text{bpy})(\text{NCS})_2$  and  $\text{Co}(\text{bpy})(\text{NCS})_2$  (bpy = 2,2'-bipyridine) have been prepared by the thermolytic decomposition of the corresponding monomeric bis(bipyridyl) complex,  $\text{M}(\text{bpy})_2(\text{NCS})_2$ . Studies by near-infrared-visible, infrared, and ESR spectroscopy and X-ray diffraction patterns indicate that the complexes are polymeric zigzag chains with stepwise metal-thiocyanate bridging groups and six-coordinate metal centers. Variable-temperature (1.5 to  $\sim 303$  K) susceptibility measurements were made for both compounds. The presence of broad susceptibility maxima centered at  $\sim 18$  K for  $\text{Mn}(\text{bpy})(\text{NCS})_2$  and at  $T < 1.5$  K for  $\text{Co}(\text{bpy})(\text{NCS})_2$  and a rapid decrease in the moment for each compound indicate antiferromagnetic exchange in the polymer chains. Such exchange is proposed to be pairwise in nature, and with use of the Heisenberg-Dirac-Van Vleck dipolar coupling model, the exchange energy,  $J$ , is estimated to be  $-2.5$   $\text{cm}^{-1}$  for  $\text{Mn}(\text{bpy})(\text{NCS})_2$ .

### Introduction

We have recently prepared a series of compounds with the empirical formula  $\text{M}(\text{bpy})(\text{NCS})_2$  in which M is divalent Mn, Fe, Co, Ni, and Cu and bpy is 2,2'-bipyridine.<sup>1</sup> Some of the properties of two members of this series,  $\text{Cu}(\text{bpy})(\text{NCS})_2$ <sup>1,2</sup> and  $\text{Fe}(\text{bpy})(\text{NCS})_2$ <sup>1,3,4</sup> have previously been reported. X-ray powder patterns of each system have revealed structural isomorphism between the manganese, iron, and cobalt analogues. The available data<sup>3</sup> indicate that  $\text{Fe}(\text{bpy})(\text{NCS})_2$  is a polymer in which all thiocyanate groups are bridging to form zigzag chains of stepwise, nearly orthogonal

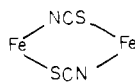

bridging groups. The structures of the present Fe, Mn, and Co compounds are most likely analogous to that recently determined for  $\text{Co}(\text{bpy})\text{Cl}_2$  in a single-crystal X-ray study<sup>5</sup> and are shown schematically in Figure 1a. The

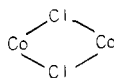

groups are found to be stepwise and nearly orthogonal. Replacement of bridging  $\text{Cl}^-$  by  $\text{NCS}^-$  should increase the

metal-metal distance within the grouping from  $\sim 3.7$  to  $\sim 6$  Å and may change the strength and/or sign of the magnetic exchange therein. This will be demonstrated in the present article. However, the gross features, stepwise polymeric chains and their packing, Figure 1b, are not expected to be significantly different for  $\text{Co}(\text{bpy})\text{Cl}_2$  vs.  $\text{Co}(\text{bpy})(\text{NCS})_2$ .

From a Mössbauer spectroscopy study between 130 and 200 K,<sup>4</sup>  $\text{Fe}(\text{bpy})(\text{NCS})_2$  is found to undergo a structural phase transition believed to be similar in nature to the  $\alpha \rightarrow \gamma$  polymer displacement transition of the linear-chain  $\text{Co}(\text{py})_2\text{Cl}_2$  that occurs at 154 K.<sup>6,7</sup> For  $\text{Fe}(\text{bpy})(\text{NCS})_2$ , the transition is believed to be the result of changes in the metal-thiocyanate bridging framework from a symmetric to an asymmetric form with decreasing temperature. Below 100 K,  $\text{Fe}(\text{bpy})(\text{NCS})_2$ <sup>3</sup> shows evidence of low-dimensional antiferromagnetic exchange characterized by a broad maximum in  $\chi_M'$  at  $\sim 18$  K and relatively large negative  $\theta$ . This exchange can be explained by assuming pairwise interactions between the iron atoms in the chain. However, for the ferrous complex there is no evidence of three-dimensional antiferromagnetic ordering for  $T$  as low as 1.5 K.

The purpose of this paper is to report the electronic, magnetic, and structural properties of  $\text{Co}(\text{bpy})(\text{NCS})_2$  and  $\text{Mn}(\text{bpy})(\text{NCS})_2$  and to compare the properties of these two systems with the isomorphous  $\text{Fe}(\text{bpy})(\text{NCS})_2$ .

### Experimental Section

The metal salts used for the preparations were reagent grade and were used without further purification. The ligand 2,2'-bipyridine

- (1) B. W. Dockum, Ph.D. Dissertation, Northeastern University, 1977.
- (2) W. M. Reiff, H. Wong, B. Dockum, T. Brennan, and C. Cheng, *Inorg. Chim. Acta*, **30**, 69 (1978).
- (3) Part 1: B. W. Dockum and W. M. Reiff, *Inorg. Chem.*, **21**, 391 (1982).
- (4) Part 2: B. W. Dockum and W. M. Reiff, *Inorg. Chem.*, **21**, 1406 (1982).
- (5) W. M. Reiff, H. Wong, G. Eisman, W. Rode, and B. Foxman, Abstracts, 179th National Meeting of the American Chemical Society, Houston, TX, March 1980, No. INOR 22.

(6) P. J. Clarke and H. J. Milledge, *Acta Crystallogr., Sect. B*, **B31**, 1543 (1975).

(7) P. J. Clarke and H. J. Milledge, *Acta Crystallogr., Sect. B*, **B31**, 1554 (1975).